

Fremdlüfteraggregat FBI, IP 66, Mb.0K VEM Brake

Forced Ventilation Unit FBI, IP 66, drw. 0K VEM Brake

Ventilation Forcée FBI, IP 66, dessin 0K VEM Brake

Gruppi per ventilazione assistita FBI, IP 66, disegno 0K VEM Brake

Grupo de ventilación asistida FBI, IP 66, diseno 0K VEM Brake

VEM

K21 Br Bg. 63 - 112 RBK

Stand: Mai 2018

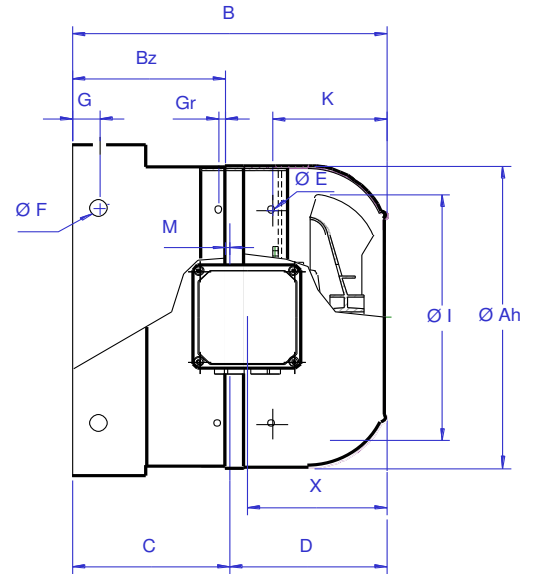
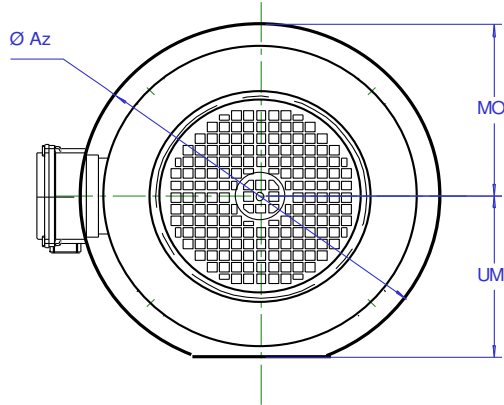
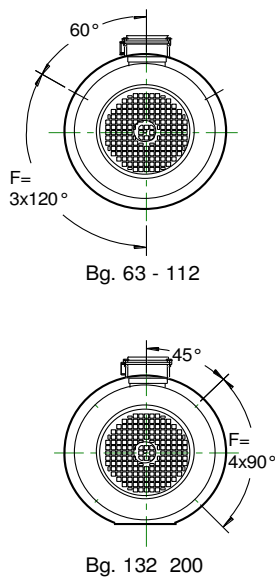

Abmessungen / Dimensions / Côtés / Dimensioni / Cotas

Baugröße Frame size Hauteur d'axe Grandezza Medelo	FBI Type FBI Type FBI Tipo	Az Ø	Ah Ø	UM	B	Bz	C	D	M	E Ø (LL)	F Ø (LL)	G	Gr	H _z	I Ø	K	X	Artikel-Nr. Item number Numéro d'article No. Articolo No. Articulo	
K21 063	63 RBK	113	121	-	206	86	90	116	-4	M4	4,8x6	6,5	5	1,0	115	57	87	FV VEM 063 OK 113 206	
K21 071	63 RBK	127	121	-	208	88	92	116	-4	M4	4,8x6	6,5	5	1,0	115	57	87	FV VEM 071 OK 127 208	
K21 080	71 RBK	141	136	-	222	130	107	115	23	M5	4,8x6	8	5	1,0	130	61	68	FV VEM 080 OK 141 222	
K21 090	80 RBK	160	154	-	237	147	124	113	23	M5	4,8x6	8	5	1,0	146	61	72	FV VEM 090 OK 160 237	
K21 100	90 RBK	180	174	-	258	158	140	118	18	M5	6x9	9	5	1,0	167	70	83	FV VEM 100 OK 180 258	
K21 112	100 RBK	200	192	-	278	168	155	123	13	M5	6x9	10	5	1,0	185	77	92	FV VEM 112 OK 200 278	

Abweichende Abmessungen (A,B,G) sowie Sonderausführungen lieferbar !
 Different dimensions (A,B,G) and special versions available !
 Deviazioni di misure (A,B,G) sono disponibili !

Possibilità di livrer differenti lunghezze (A,B,G) modelli hors série !
 Diferencias de cotas (A,B,G) pueden ser entregadas !

Kurt Maier Motor-Press GmbH

Birkenweg 18 DE - 37589 Kalefeld

☎ +49 (0) 5553 / 99 01-0 ☎ +49 (0) 5553 / 99 01 88 ✉ E-mail: info@kmmp.de <http://www.kmmp.de>

