

Weitere Rotorbohrungen und Eisenlängen in mm auf Anfrage.
 Non-standard rotor bores and stator core length available upon request.

Autres alésages rotateurs et longueur fer en mm sur demande.

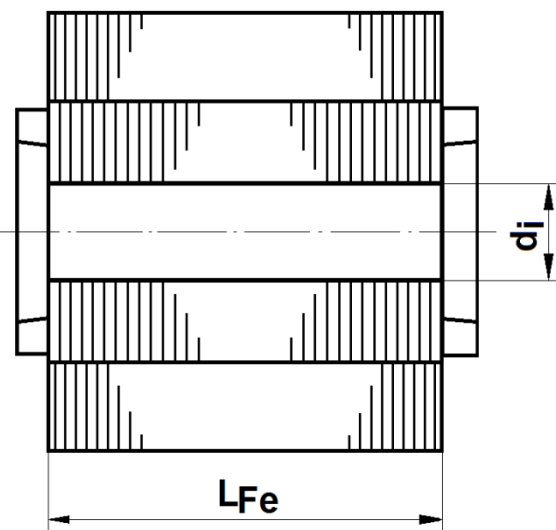
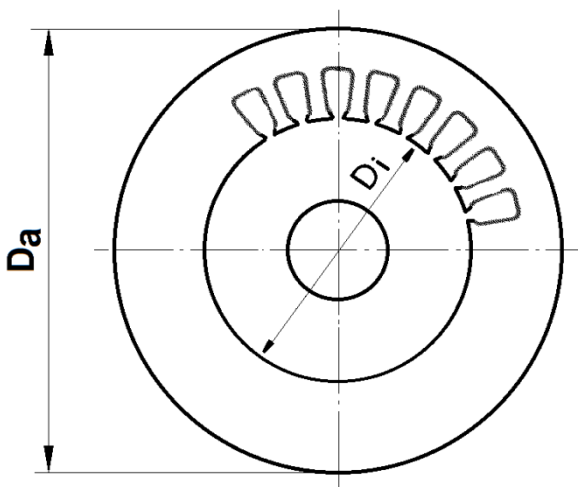

Baugröße Frame size Hauteur d'axe	kW	Abmessungen / Dimensions / Cotes						Artikel-Nr. / Item number / Numero d' article	
		L Fe	Da	DI	di	Nz Stator	Nz Rotor	Stator	Rotor
56	0,03	45	80	50	15	36	30	SSA056 6 0045 015	SRA056 6 0045 015
	0,04	55						SSA056 6 0055 015	SRA056 6 0055 015
63	0,06	45	90	55	18	36	30	SSA063 6 0045 018	SRA063 6 0045 018
	0,09	60						SSA063 6 0060 018	SRA063 6 0060 018
71	0,12	50	106,5	70	20	36	30	SSA071 6 0050 020	SRA071 6 0050 020
	0,18	65						SSA071 6 0065 020	SRA071 6 0065 020
80	0,25	70	120	80	25	36	30	SSA080 6 0070 025	SRA080 6 0070 025
	0,37	90						SSA080 6 0090 025	SRA080 6 0090 025
90S	0,45	75	135	90	30	36	30	SSA090 6 0075 030	SRA090 6 0075 030
90L	0,55	100						SSA090 6 0100 030	SRA090 6 0100 030
100L	0,75	90	150	103	36	36	34	SSA100 6 0090 036	SRA100 6 0090 036
	1,1	120						SSA100 6 0120 036	SRA112 6 0120 038
112M	1,5	140	170	115	38	36	34	SSA112 6 0140 038	SRA132 6 0140 050

Weitere Rotorbohrungen und Eisenlängen in mm auf Anfrage.
Non-standard rotor bores and stator core length available upon request.

Autres alésages rotateurs et longueur fer en mm sur demande.

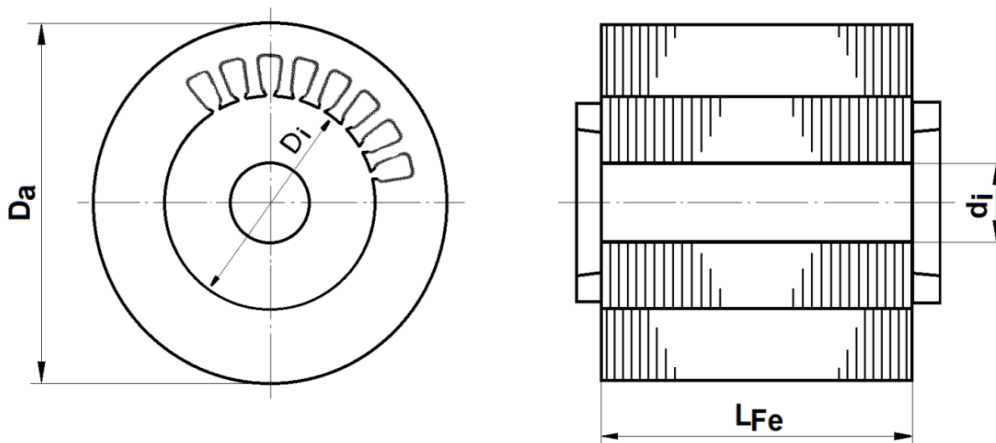

Baugröße Frame size Hauteur d'axe	kW	Abmessungen / Dimensions / Cotes						Artikel-Nr. / Item number / Numero d' article	
		L Fe	Da	DI	di	Nz Stator	Nz Rotor	Stator	Rotor
132S	2,2	100	200	140	50	48	44	SSA132 8 0100 050	SRA132 8 0100 050
132M	3	135						SSA132 8 0135 050	SRA132 8 0135 050
160M	4	125	240	170	55	48	44	SSA160 8 0125 055	SRA160 8 0125 055
	5,5	165						SSA160 8 0165 055	SRA160 8 0165 055
160L	7,5	225						SSA160 8 0225 055	SRA160 8 0225 055
180L	11	240	270	190	65	48	44	SSA180 8 0240 065	SRA180 8 0240 065
200L	15	265	300	215	75	48	44	SSA200 8 0265 075	SRA200 8 0265 075
225S	18,5	240	340	240	80	48	44	SSA225 8 0240 080	SRA225 8 0240 080
225M	22	290						SSA225 8 0290 080	SRA225 8 0290 080
250M	30	310	375	270	85	48	44	SSA250 8 0310 085	SRA250 8 0310 085
280S	37	300	420	305	95	72	60	SSA280 8 0300 095	SRA280 8 0300 095
280M	45	360						SSA280 8 0360 095	SRA280 8 0360 095
315S	55	300	500	375	115	72	60	SSA315 8 0300 115	SRA315 8 0300 115
315M	75	370						SSA315 8 0370 115	SRA315 8 0370 115
	90	450						SSA315 8 0450 115	SRA315 8 0450 115
	110	550						SSA315 8 0550 115	SRA315 8 0550 115
355S	132	470	580	425	130	72	84	SSA355 8 0470 130	SRA355 8 0470 130
	160	550						SSA355 8 0550 130	SRA355 8 0550 130
355L	132	470						SSA355 8 0470 130	SRA355 8 0470 130
	160	550						SSA355 8 0550 130	SRA355 8 0550 130