

## Anschluß Schema FBI MW, IP66 Mb.0M / 1M

Connection Table Forced Ventilation Unit MW, IP66 Mb.0M / 1M  
 Schéma de branchement Ventilation Forcée FBI MW, IP66 Mb.0M / 1M  
 Schema di collegamento FBI MW, IP66 Mb.0M / 1M  
 Esquema de conexión FBI MW, IP66 Mb.0M / 1M

**kmmp.**

**Bg. 56 - 225**

Stand: April 2015

- D** **Achtung!** Der Motor wurde gegen Körperschluß geprüft mit 2200V, 30mA gem. VDE! Bei einer Wiederholungsprüfung max. 1.000V anlegen um einen Wicklungsschaden zu vermeiden!
- GB** **Attention!** This motor is tested against body current with 2200V, 30mA following VDE! If a further test is carried out at client, it must not exceed 1.000V in order to prevent winding damage!
- F** **Attention!** Ce moteur a subi un test d'isolement sous une tension de 2200V, 30mA d'après VDE! Chaque nouveau test doit être effectué sous une tension max. de 1.000V afin de ne pas endommager le bobinage!
- I** **Attenzione!** Il motore è stato mantenuto alla prova di corto circuito con 2200V, 30mA secondo VDE! In caso di ripetizione dalla prova non usare più di max. 1.000V per evitare danno dal avvolgimento!
- E** **Atencion!** El motor ha estado mantenido a la prueba de cortocircuito con 2200V, 30mA según VDE! En caso de repetición de la prueba, usar como max. 1.000V para evitar una avería del bobinado!

Drehstrommotor  
 Three phase motor  
 Moteur asynchrone triphasée  
 Motore trifase  
 Motor trifásico

Drehstrommotor in 1-Phasen „Steinmetz“ Schaltung  
 Three phase motor in single phase connection acc. to „Steinmetz“  
 Moteur asynchrone triphasée en couplage „Steinmetz“  
 Motore trifase in collegamento „Steinmetz“ in 1-fase  
 Motor trifásico en conexión „Steinmetz“ en 1-fase

3~

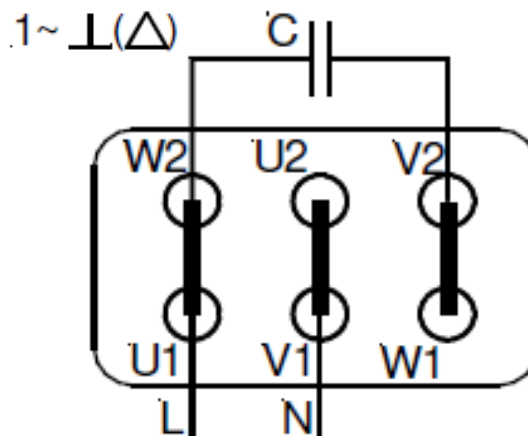
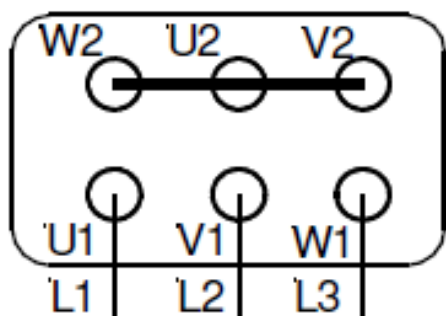

3~ Δ

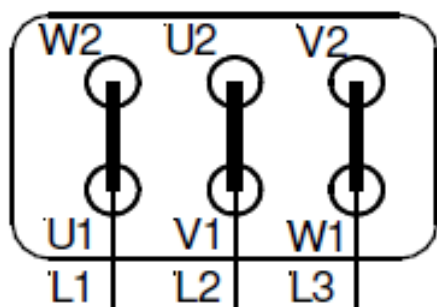

U1	(T1)	schwarz	black	noire	nero	negro
V1	(T2)	blau	blue	bleue	azzurro	azul
W1	(T3)	braun	brown	brune	marrone	márron
U2	(T4)	grün	green	verde	verde	verde
V2	(T5)	weiß	white	blanche	bianco	blanco
W2	(T6)	gelb	yellow	jaune	giallo	amarillo
		grün-gelb	green-yellow	verde-jaune	verde-giallo	verde-amarillo
C		Kondensator	Capacitor	Condensateur	condensatori	condensatore

**! Bitte Drehrichtung vom Flügel beachten / Please check the rotational direction of the impeller !**

**Kurt Maier Motor-Press GmbH**

Birkenweg 18 \* D-37589 Kalefeld

+49 (0) 5553 99 01-0 \* +49 (0) 5553 99 01-88 \* info@kmmp.de \* http://www.kmmp.de

**kmmp.**