

Fremdlüfteraggregat FBI, IP 66, Mb. 2K & 3K VEM

Forced Ventilation Unit FBI, IP 66, drw. 2K & 3K VEM

Ventilation Forcée FBI, IP 66, dessin 2K & 3K VEM

Gruppi per ventilazione assistita FBI, IP 66, disegno 2K & 3K VEM

Grupo de ventilación asistida FBI, IP 66, diseño 2K & 3K VEM

VEM

K21F Bg. 112 - 315-14 V-RBK

Stand: Jan. 10

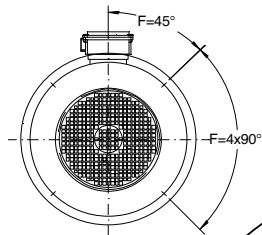

Bg. 112 - 315

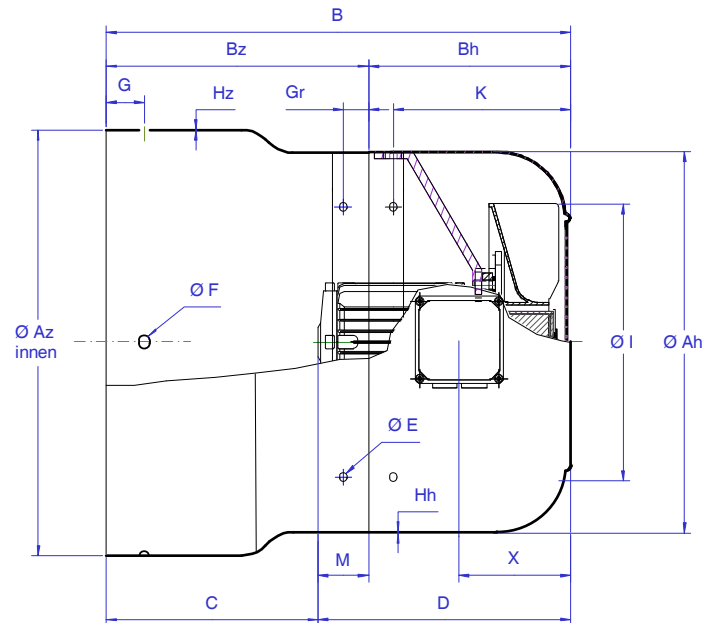
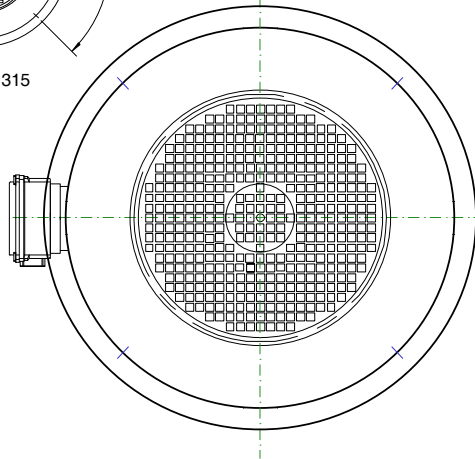

Abmessungen / Dimensions / Côtes / Dimensioni / Cotas

Baugröße Frame size Hauteur d'axe Grandezza Medelo	FBI Type FBI Type FBI Tipo	Az Ø	Ah Ø	B	Bz	C	D	M	E Ø (LL)	F Ø (LL)	G	Hh	H _z	I Ø	K	X	Gr	Artikel-Nr. Item number Numéro d'article No. articolo No. articula
K21F 112	100-2 V-RBK	200	192															
K21F 132-1	112-2 V-RBK	234	216	323	153	123	200	30	6x9	7,5	15	1,5	1,5	209	154	100	25	FV VEM 132 2K 234 323
K21F 160-2	132-2 V-RBK	278	255	338	168	140	198	28	6x9	7,5	27	1,5	1,5	209	147	100	25	FV VEM 160 2K 278 338
K21F 160-3	132-2 V-RBK	278	255	409	239	211	198	28	6x9	7,5	27	1,5	1,5	209	147	100	25	FV VEM 160 2K 278 409
K21F 160-4	132-4 V-RBK	278	255															
K21F 180-5	132-2 V-RBK	338	255	413	243	215	198	28	6x9	7,5	27	1,5	1,5	209	147	100	25	FV VEM 180 2K 338 413
K21F 180-6	160-4 V-RBK	338	307	396	259	176	220	83	7x14	7,5	27	1,5	1,5	295	111	75	25	FV VEM 180 3K 338 396
K21F 200-7	180-2 V-RBK	382	345															
K21F 200-8	180-4 V-RBK	382	345	390	235	170	220	65	7x14	7,5	26	1,5	1,5	295	120	85	25	FV VEM 200 3K 382 390
K21F 200-9	200-4 V-RBK	382	382	395	217	175	220	42	7x14	7,5	26	1,5	1,5	295	140	105	25	FV VEM 200 3K 382 395
K21F 225-10	180-2 V-RBK	421	345															
K21F 225-10,11	200-4 V-RBK	421	382	400	222	180	220	42	7x14	7,5	29	1,5	1,5	295	140	105	25	FV VEM 225 3K 421 400
K21F 250-12	250-4 V-RBK	477	477	452	232	182	270	50	9x16	9,5	33	1,5	2,0	400	174	135	25	FV VEM 250 3K 477 452
K21F 280-13	280-4 V-RBK	536	533	456	218	188	268	30	9x16	9,5	35	1,5	2,0	400	189	150	25	FV VEM 280 3K 536 456
K21F 315-14	315-4 V-RBK	605	597	472	215	205	267	10	9x16	9,5	38	1,5	2,0	400	207	170	25	FV VEM 315 3K 605 472

Abweichende Abmessungen (A, B, G) sowie Sonderausführungen lieferbar! / Different diameters (A, B, G), special versions available!
 Possibilité de livrer différents longueurs (A, B, G) modèles 'hors série' / Deviazione di misure (B,G) sono disponibili!
 Diferencias de cotas (B,G) pueden ser entregadas!

Kurt Maier Motor-Press GmbH

Birkenweg 18 * DE - 37589 Kalefeld

☎ +49(0)5553 99 01 0 * 📠 +49(0)5553 99 01 88 * ✉ E-mail: info@kmmp.de * <http://www.kmmp.de>



Fremdlüfteraggregat FBI, IP 66, Mb. 2K & 3K VEM

Forced Ventilation Unit FBI, IP 66, drw. 2K & 3K VEM

Ventilation Forcée FBI, IP 66, dessin 2K & 3K VEM

Gruppi per ventilazione assistita FBI, IP 66, disegno 2K & 3K VEM

Grupo de ventilación asistida FBI, IP 66, diseño 2K & 3K VEM

VEM

K21F Bg. 132-15 - 355-26 V-RBK

Stand: Jan. 10

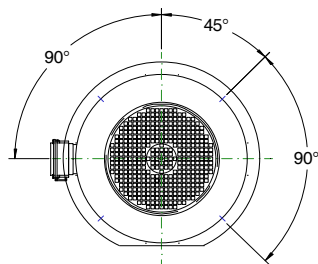

Bg. 225 - 355

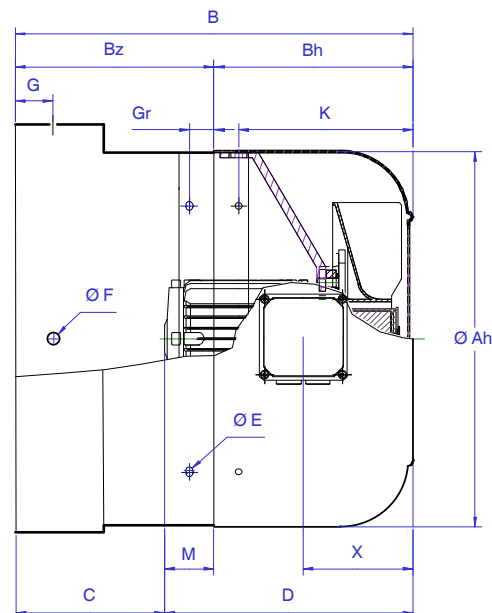
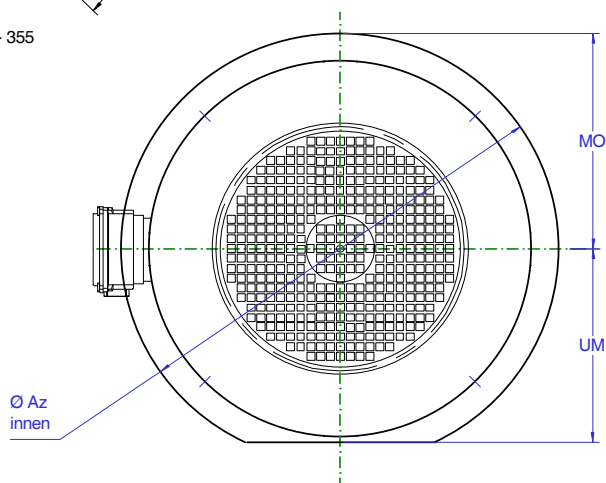

Abmessungen / Dimensions / Côtes / Dimensioni / Cotas

Baugröße Frame size Hauteur d'axe Grandezza Medelo	FBI Type FBI Type FBI Tipo	Az Ø	Ah Ø	UM	MO	B	Bz	C	D	M	E Ø (LL)	F Ø (LL)	G	H _z	I Ø	K	X	Gr	Artikel-Nr. Item number Numéro d'article No. articolo No. articula
K21F 132-15	112-2 V-RBK	278	216	127	139	340	170	140	200	30	6x9	7,5	27	1,5	209	154	100	25	FV VEM 132 2K 278 340
K21F 132-16	132-2 V-RBK	278	255	129	139	409	239	211	198	28	6x9	7,5	27	1,5	209	147	100	25	FV VEM 132 2K 278 409
K21F 160-17	132-2 V-RBK	338	255	155	169	413	243	215	198	28	6x9	7,5	27	1,5	209	147	100	25	FV VEM 160 2K 338 413
K21F 160-18	160-2 V-RBK																		
K21F 160-19	160-4 V-RBK																		
K21 F 180-20	180-2 V-RBK																		
K21F 200-21	180-2 V-RBK																		
K21F 315-22	315-4 V-RBK																		
K21F 315-23	315-4 V-RBK																		
K21F 315-24	315-4 V-RBK																		
K21F 280-25	250-4 V-RBK																		
K21F 355-26	355-4 V-RBK	764	691	345	382	701	458	426	275	32	9x16	9,5	50	2	530	193	150	25	FV VEM 355 3K 764 701
K20F 112-27	112-2 V-RBK	234	216	108	117	460	290	260	200	30	6x9	6x9	15	1,5	209	154	100	25	FV VEM 112 2K 234 460

Abweichende Abmessungen (A, B, G) sowie Sonderausführungen lieferbar! / Different diameters (A, B, G), special versions available!

Possibilité de livrer différents longueurs (A, B, G) modèles 'hors série' / Deviazione di misure (B,G) sono disponibili!

Diferencias de cotas (B,G) pueden ser entregadas!

Kurt Maier Motor-Press GmbH

Birkenweg 18 * DE - 37589 Kalefeld

☎ +49(0)5553 99 01 0 * 📠 +49(0)5553 99 01 88 * ✉ E-mail: info@kmmp.de * <http://www.kmmp.de>



Fremdlüfteraggregat FBI, VEM

Forced Ventilation Unit FBI, VEM

Ventilation Forcée FBI, VEM

Gruppi per ventilazione assistita FBI, VEM

Grupo de ventilación asistida FBI, VEM

VEM

Zuordnung /assignment

Stand: Jan 08

VEM-Motor - Typ		VEM-Motor - Typ		FBI-Typ	IP 54 SP/EK	
KPER / K11R		KPR / K10R		IP 55 / 66		
K21R / KMER / SPER		K20R / KMR / SPR				
KPER 63		KPR 56		⇒	KPEF 63	KPEF 63 SP
KPER 71		KPR 63		⇒	KPEF 71	KPEF 71 SP
KPER 80		KPR 71		⇒	KPEF 80	KPEF 80 SP
KPER 90		KPR 80		⇒	KPEF 90	KPEF 90 SP
KPER 100		KPR 90		⇒	KPEF 100	KPEF 100 EK
KPER 100	LX	KPR 100		⇒	KPEF 112	KPEF 112 EK
KPER 112		KPR 100		⇒	KPEF 112	KPEF 112 EK
KPER 132 T	VEM Thurm			⇒	KPEF 112	
KPER 132	S 2,4,6,8	KPR 112	M 4,6,8	⇒	KPEF 132 - 1	
KPER 132	SX 2	KPR 112	M 2	⇒	KPEF 132 - 1	
KPER 132	M 4	KPR 132	S 4	⇒	KPEF 132 - 16	
KPER 132	M 6,8	KPR 112	MX 6,8	⇒	KPEF 132 - 1	
KPER 132	MX 6	KPR 132	S 6	⇒	KPEF 132 - 15	
KPER 160	M 2,4	KPR 132	M 2,4	⇒	KPEF 160 - 3	
KPER 160	M 6	KPR 132	M 6	⇒	KPEF 160 - 2	
KPER 160	M 8	KPR 132	S 8	⇒	KPEF 160 - 4	
KPER 160	MX 2	KPR 160	S 2	⇒	KPEF 160 - 18	
KPER 160	MX 8	KPR 132	M 8	⇒	KPEF 160 - 4	
KPER 160	L 2	KPR 160	M 2	⇒	KPEF 160 - 18	
KPER 160	L 4	KPR 160	S 4	⇒	KPEF 160 - 17	
KPER 160	L 6,8	KPR 160	S 6,8	⇒	KPEF 160 - 19	
KPER 180	M 2	KPR 180	S 2	⇒	KPEF 180 - 20	
KPER 180	M 4	KPR 160	M 4	⇒	KPEF 180 - 5	
KPER 180	L 4	KPR 180	S 4	⇒	KPEF 180 - 20	
KPER 180	L 6,8	KPR 160	M 6,8	⇒	KPEF 180 - 6	
KPER 200	L 2	KPR 180	M 2	⇒	KPEF 200 - 7	
KPER 200	L 4	KPR 180	M 4	⇒	KPEF 200 - 9	
KPER 200	L 6,8	KPR 180	S 6,8	⇒	KPEF 200 - 8	
KPER 200	LX 2	KPR 200	M 2	⇒	KPEF 200 - 21	
KPER 200	LX 6	KPR 180	M 6	⇒	KPEF 200 - 8	
KPER 225	S 4	KPR 200	M 4	⇒	KPEF 225 - 10	
KPER 225	S 8				KPEF 225 - 11	
KPER 225	M 2,4	KPR 200	L 2,4	⇒	KPEF 225 - 10	
KPER 225	M 6,8	KPR 200	M 6,8	⇒	KPEF 225 - 11	
KPER 250	M 2,4,6,8	KPR 225	M 2,4,6,8	⇒	KPEF 250 - 12	
KPER 280	S 2,4,6,8	KPR 250	S 2,4,6,8	⇒	KPEF 280 - 13	
KPER 280	M 2,4,6,8	KPR 250	M 2,4,6,8	⇒	KPEF 280 - 13	
KPER 315	S 2,4,6,8	KPR 280	S 2,4,6,8,10	⇒	KPEF 315 - 14	
KPER 315	M 2,4,6,8	KPR 280	M 2,4,6,8	⇒	KPEF 315 - 14	
KPER 315	MX 2,4,6,8	KPR 315	S 2,4,6,8	⇒	KPEF 315 - 14	
KPER 315 (KPER)	MY 2,4,6,8 (alt)	KPR 315	M 2,4,6,8	⇒	KPEF 315 - 22	
K11R 315						
(K11R / K21R)	L, MY 2,4,6,8 (neu)			⇒	KPEF 315 - 23	
KPER 315	LX 2,4			⇒	KPEF 315 - 24	
KPER 355	MX 4,6 M4,6,			⇒	KPEF 355 - 26	

Kurt Maier Motor-Press GmbH

Birkenweg 18 * DE - 37589 Kalefeld

☎ +49(0)5553 99 01 0 * 📠 +49(0)5553 99 01 88 * ✉ E-mail: info@kmmp.de * <http://www.kmmp.de>

