

# Fremdlüfteraggregat FBI, IP 66, Mb. 1K/1E DUT

Forced Ventilation Unit FBI, IP 66, drw. 1K/1E DUT

Ventilation Forcée FBI, IP 66, dessin 1K/1E DUT

Gruppi per ventilazione assistita FBI, IP 66, disegno 1K/1E DUT

Grupo de ventilación asistida FBI, IP 66, diseño 1K/1E DUT

# Dutchi

DM1

Bg. 160 – 355 RBK

Stand: Nov. 08

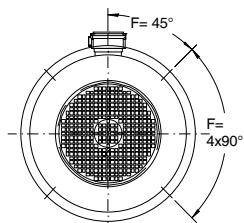

DM1 160 - 355

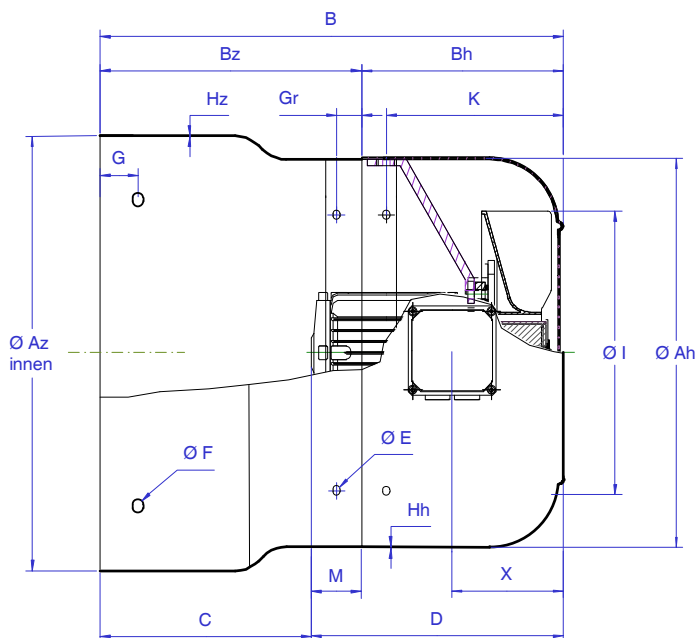
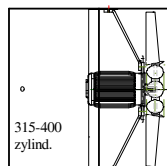
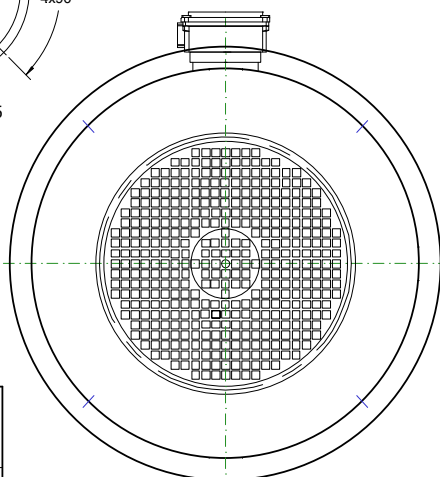

## Abmessungen / Dimensions / Côtes / Dimensioni / Cotas

Baugröße Frame size Hauteur d'axe Grandezza Medelo	FBI Type FBI Type FBI Tipo	Az Ø	Ah Ø	B	Bz	C	D	M	E Ø (LL)	F Ø (LL)	G	Hh	Hz	I Ø	K	X	Gr	Artikel-Nr. Item number Numéro d'article No. articolo No. articula
DM1 160	160-4 RBK	312	307	395	259	148	247	111	M6	6x9	20	1,5	1,5	295	111	75	25	FV DUT 160 1K 312 395
DM1 180	180-4 RBK	354	345	482	327	235	247	92	M6	7x14	39	1,5	1,5	295	120	85	25	FV DUT 180 1K 354 482
DM1 200	200-4 RBK	396	382	482	304	235	247	69	M6	7x14	39	1,5	1,5	295	140	105	25	FV DUT 200 1K 396 482
DM1 225	225-4 RBK	430	430	465	273	221	244	52	M6	9x16	45	1,5	1,5	295	150	115	25	FV DUT 225 1K 430 465
DM1 250	250-4 RBK	477	477	559	339	250	309	89	M8	9x16	55	1,5	2	400	174	135	25	FV DUT 250 1K 477 559
DM1 280	280-4 RBK	533	533	560	322	260	300	62	M8	9x16	69	1,5	2	400	189	150	25	FV DUT 280 1K 533 560
DM1 315	315-4 RBK	597	597	637	380	340	297	40	M8	12	75	1,5	2	400	207	170	25	FV DUT 315 1K 597 637
	Zylindrische Hauben-Ausführung																	
DM1 315	315-4 RBK	597	597	667	410	340	327	70	M8	12	75	2,5	2,5	575	222	145	25	FV DUT 315 1K 597 667
DM1 355	355-4 RBK	694	691	714	471	381	333	90	M8	14	114	2,5	2,5	660	208	130	25	FV DUT 355 1K 694 714
	400-4 RBK	781					333	90	M8			2,5	2,5	740	208	130	25	

Abweichende Abmessungen (A, B, G) sowie Sonderausführungen lieferbar!

Different diameters (A, B, G), special versions available!

Possibilità di livrer differenti lunghezze (A, B, G) modelli 'hors série'!

Deviazioni di misure (B,G) sono disponibili!

Diferencias de cotas (B,G) pueden ser entregadas!

## Kurt Maier Motor-Press GmbH

Birkenweg 18 \* D-37589 Kalefeld

☎ (05553) 99 01-0 \* 📠 (05553) 49 67 \* ✉ E-mail: wm@kmmp.de \* <http://www.kmmp.de>



# Fremdlüfteraggregat FBI, IP 66, Mb. 1K/1E DUT

Forced Ventilation Unit FBI, IP 66, drw. 1K/1E DUT

Ventilation Forcée FBI, IP 66, dessin 1K/1E DUT

Gruppi per ventilazione assistita FBI, IP 66, disegno 1K/1E DUT

Grupo de ventilación asistida FBI, IP 66, diseño 1K/1E DUT

# Dutchi

DM1-G

Bg. 160 – 355 RBK

Stand: Juli 09

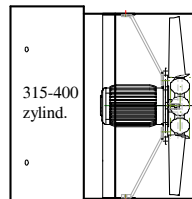
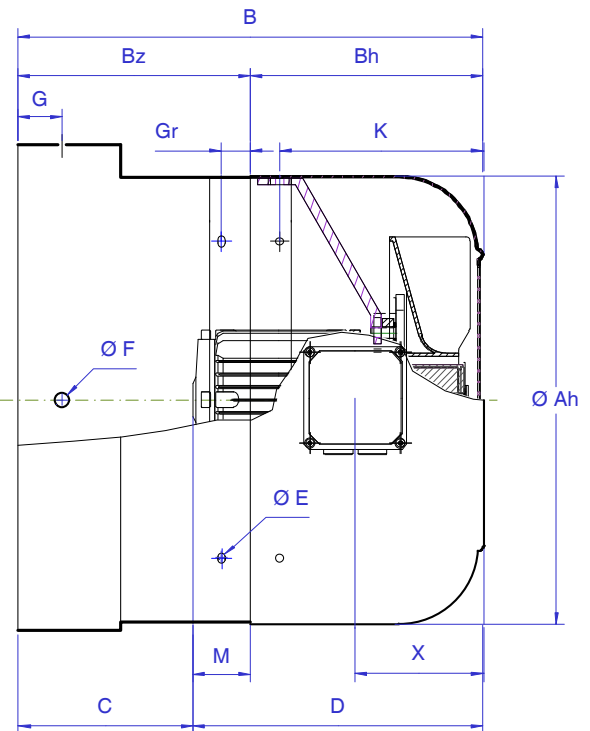
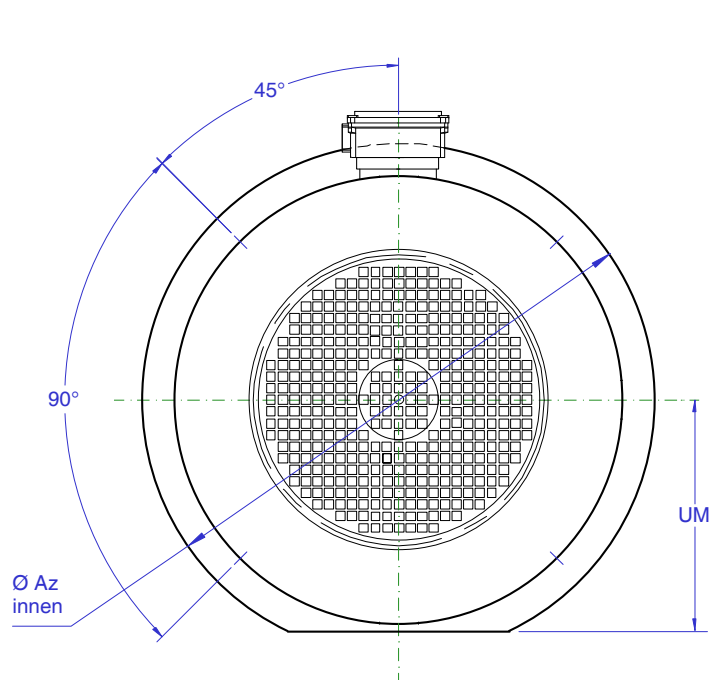

## Abmessungen / Dimensions / Côtes / Dimensioni / Cotas

Baugröße Frame size Hauteur d'axe Grandezza Medelo	FBI Type FBI Type FBI Tipo	Az Ø	Ah Ø	UM	B	Bz	C	D	M	E Ø (LL)	F Ø (LL)	G	Gr	K	I Ø	Artikel-Nr. Item number Numéro d'article No. Articolo No. Articola
DM1G 160	160 RBK	352	307	156	397	261	150	247	111	M6	6x9	10	25	111	295	FV DUT 160 1K 352 397
DM1G 200	200 RBK	430	382	196	432	254	185	247	69	M6	7x14	20	25	140	295	FV DUT 200 1K 430 432
DM1G 225	225 RBK	470	430	218	449	257	205	244	52	M6	9x16	30	25	150	295	FV DUT 225 1K 470 449
DM1G 250	250 RBK	513	477	238	534	314	225	309	89	M8	9x16	40	25	174	400	FV DUT 250 1K 513 534
DM1G 280	280 RBK	583	533	270	580	342	280	300	62	M8	9x16	45	25	189	400	FV DUT 280 1K 583 580
DM1G 315	315 RBK	665	597	308	637	380	340	297	40	M8	12x20	75	25	207	400	FV DUT 315 1K 665 637
Zylindrische Hauben-Ausführung																
DM1G 315	315 RBK	665	597	308	667	410	340	327	70	M8	12x20	75	25	222	575	FV DUT 315 1K 665 667
DM1G 355	355 RBK	692	691	-	713	470	380	333	90	M8	14	114	25	208	660	FV DUT 355 1K 692 713
DM1G																

Abweichende Abmessungen (A, B, G) sowie Sonderausführungen lieferbar!

Different diameters (A, B, G), special versions available!

Possibilité de livrer différents longueurs (A, B, G) modèles 'hors série'!

Deviazione di misure (B,G) sono disponibili!

Diferencias de cotas (B,G) pueden ser entregadas!

## Kurt Maier Motor-Press GmbH

Birkenweg 18 \* D-37589 Kalefeld

☎ (05553) 99 01-0 \* 📠 (05553) 49 67 \* ✉ E-mail: wm@kmmp.de \* <http://www.kmmp.de>

