



AVTRON MANUFACTURING, INC.
 8901 E. PLEASANT VALLEY ROAD
 INDEPENDENCE, OHIO 44131-5508
TELEPHONE: (1) 216-642-1230 • **FAX:** (1) 216-642-6037
E-MAIL: tachs@avtron.com • **WEB:** www.avtronencoders.com

Encoder Instructions

M4-3 thru M4-9 M4-A thru M4-F

HOLLOW SHAFT

DESCRIPTION

The Avtron Model M4-3, M4-4, M4-5, M4-6, M4-7, M4-8, M4-9, M4-A, M4-B, M4-C, M4-D, M4-E, and M4-F Hollow Shaft Encoders are severe duty speed and position incremental transducers (also known as tachometers or rotary pulse generators). When mounted to a motor or machine, their output is directly proportional to shaft position (pulse count) or speed (pulse rate). The M4 operates down to zero speed and can be used for both control and instrumentation applications.

The M4 Hollow Shaft Encoders eliminate the need for shaft couplings, adapter flanges, or accessory mounting faces. The unit employs a hollow shaft and clamping collar to lock the encoder to the shaft. An anti-rotation bracket prevents rotation of the encoder while allowing for shaft end float.

The enclosures on all Model M4s help protect the internal components from the entry of dust and liquids. This, along with the fact that the M4 uses magnetoresistive sensing technology, makes the M4 ideal for demanding industries like paper, metals, and chemical processing.

All M4s can be equipped with one or two outputs. Each output is electrically independent and totally isolated.

These outputs are available as single phase; two-phase (A,B) 90° apart for direction sensing; with complements (\bar{A}, \bar{B}), (A Quad B Output), and with marker pulse (Z, \bar{Z}). Output resolution is determined by the rotor's base PPR (pulses per revolution), times a sensor multiplier. The sensor module can provide: 1/2 the base PPR, the base PPR, or double the base PPR (see table). With two outputs, the same encoder can provide two different PPRs from a given rotor at the same time. Only one rotor per encoder is possible.

Example: an M4 could use a 1024 PPR sensor output on one side for feedback to a drive system, and simultaneously use a 256 PPR sensor on the other side for a process computer.

Refer to separate instructions for additional information on the shaft grounding option.

	AVAILABLE RESOLUTIONS		
	-48 OPTION	-51 OPTION	-60 OPTION
LOW	240	256	300
MEDIUM	480	512	600
HIGH	960	1024	1200

INSTALLATION CONSIDERATIONS

The M4 hollow shaft encoder requires a minimum mounting shaft length, a minimum clearance space, and a precise shaft diameter tolerance for proper mounting. See the table on the back page for shaft requirements by model.

The M4 standard flexible anti-rotation bracket will tolerate $\pm 0.1"$ of shaft end float. Consideration should be taken when positioning the encoder.

CAUTION

Be careful not to damage clamping fingers during handling. Do not tighten clamping collar before installation onto motor shaft. Damaging clamping fingers can affect the quality of installation.

NOTE

In some cases units are shipped with a protective plug in the hollow shaft to help prevent damage. If it is present, it must be removed prior to final installation.

INSTALLATION

Equipment needed for installation

Supplied:

- | | |
|--|----------------------------------|
| 1. M4 Encoder | 7. Washer, Flat 1/4 (2) |
| 2. Clamping Collar | 8. Washer, Spring Lock 1/4 |
| 3. Anti-Rotation Bracket | 9. Washer, Tooth Lock 3/8 (2) |
| 4. Thread Locker (blue) | 10. Nut, Hex 1/4-20 |
| 5. Screw, Button Hd., 3/8-16 x .50 (2) | 11. Washer, Shoulder, Insulating |
| 6. Screw, Socket Hd. Cap. 1/4-20 x .62 | 11. Washer, Flat, Insulating |
| | 12. Anti-Seize Compound (copper) |

M4 PART NUMBERS AND AVAILABLE OPTIONS

Model	Bore Size	Mounting Style	Line Driver	Left & Right Output Range	BASE PPR	Marker	Connector	Modifications
M4-	0- Non-Standard 3- 5/8" B-12mm A- 3/4" C-16mm 4- 1" F-25mm 5- 1 1/8" D-52mm 8- 1 1/2" E-58mm 9- 1 5/8" 6- 2" 7- 2 3/8"	S- End of Shaft T- Thru Shaft G- End of Shaft with Grounding R- Thru Shaft with Grounding	1- 5 to 24 VDC 2- 5 to 18 VDC 3- 18 to 24 VDC 4- 5 to 24 V in, 5 V fixed out	X- None L- Low Range (Base PPR x 1/2) M- Medium Range (Base PPR x 1) H- High Range (Base PPR x 2)	48- 480 51- 512 60- 600	Z- Marker -- None		000- None 003- Torque Arm Mount 005- -40° C Rating 007- Fan Cover Mount 008- 4.5" C-Face Mount 009- Northstar Pinout 015- Stainless Steel Shaft 016- 8.5" C-Face Mount 023- Dynapar Pinout (MS) 028- 12.5" C-Face Mount 035- Insulated Shaft
Connector								
10 Pin Connector				5 Pin MS Connector		Conduit Box		3 ft. Flex. Cable
MS		MS mini		EPIC		M737A replacement		W- Sealed, Pigtail
A- without Plug ^s B- with Flex. Conduit Adapter ^s C- with Plug ^s		K- with Flex. Conduit Adapter ^b L- elbow with Plug ^b M- without Plug ^b		R- Baldor without Plug S- Baldor on 3 ft. Pigtail		P- with Plug V- without Plug		X- Sealed, Industrial Connector without Plug Z- Sealed, Industrial Connector with Plug
						M727A replacement H- without Plug ^s J- with Plug ^s		N- with color coded leads T- with Terminal Block

^s side exit ^b bottom exit

Not Supplied:

- 5/32" Hex Wrench (T-Handle Style) (M4-B only)
- 3/16" Hex Wrench (T-Handle Style) (M4-3, -4, -5, -A, -C, -F only)
- 7/32" Hex Wrench (T-Handle Style)
- 1/4" Hex Wrench (T-Handle Style) (M4-6, -8, -9, -D only)
- 5/16" Hex Wrench (T-Handle Style) (M4-7, -E only)
- 7/16" Wrench
- Dial Indicator

Optional:

- Torque Arm
- Fan Cover Mounting Kit
- C-Face Mounting Kits

Clean machine shaft of any dirt and check for any burrs or damage.

Install the anti-rotation bracket to the back of the M4 using 3/8-16 screws and thread locker.

Remove screws from clamping collar, apply thread locker to screw threads and reinstall. Place clamping collar loosely on the inboard end of the shaft. Carefully slide M4 onto the shaft. **DO NOT FORCE.** Encoder should slide on easily. After verifying M4 fit onto shaft, remove M4, apply anti seize supplied to shaft and re-install M4 (see shaft engagement). Tighten screws on clamping collar evenly until snug, then firmly tighten. **DO NOT USE A STANDARD RIGHT ANGLE WRENCH.** Use only a T-handle hex wrench or torque wrench with hex bit.

Secure free end anti-rotation bracket to frame. Use supplied insulating hardware if necessary as shown. Adapter kits are available for NEMA 56C (A24492) and 8 1/2" (A24493) mounting faces.

Shaft Engagement

See table on last page.

For shaft lengths greater than the maximum engagement allowed, end of shaft mounting may still be employed by locating the encoder away from the motor using a spacer between the motor and anti-rotation bracket.

Corrective Action for Excess Housing Movement (Wobble)

The hollow shaft M4 design eliminates the potential for bearing and coupling failures from misalignment, however, excessive housing movement (wobble) may cause undesirable vibrations. The higher the RPM, the more severe the vibration will be from

housing movement. In a typical installation a housing movement of 0.007" TIR or less (as measured at the outside diameter of the main encoder body) will not have an adverse effect. If excessive housing movement is detected in the installation:

- 1) Check the shaft the M4 is mounted on for excessive shaft runout. NEMA MG1 calls for 0.002" TIR or less.
- 2) Verify that the M4 engagement with the motor shaft conforms to the engagement rules on page 4. In general, maximizing engagement will minimize housing movement.
- 3) Verify that the mounting shaft diameters conform to the rules on page 4. Excessive housing movement occurs when the clearance between the motor shaft and pulse generator shaft allows the two center lines to miss match.
- 4) Loosen the clamping collar and rotate the motor shaft 180° within the M4 hollow shaft sleeve.
- 5) Make sure the clamping collar is tightened equally on both sides.
- 6) Move the split in the clamping collar over a solid portion of the M4 shaft.

If excessive housing movement still exists after the above steps, it may be necessary to physically bias the attitude of the encoder on the motor shaft while the clamping collar is being tightened. Either by eye or using dial indicators, note the position around the outside diameter of the encoder that is most out of position from true while turning the motor shaft slowly. With the motor shaft no longer turning, loosen the clamping collar. While applying moderate force by hand against the outside diameter of the encoder on the side opposite where the out of true position was observed, retighten the clamping collar. Several iterations may be necessary if the first attempt under or over compensates. This method may be used to help compensate for undersized shafts, shaft runout, bent clamping fingers, and other problems.

BREATHER/DRAIN CONSIDERATIONS

Because the M4 incorporates magnetoresistive sensing technology it can be fitted with a breather drain. The M4 is shipped standard with a breather/drain in the bottom. The breather is to equalize pressure if the tach is exposed to temperature variations. With a sealed encoder, pressure variations can potentially lead to contamination of bearing grease when the encoder is exposed to rapid temperature changes typically associated with being washed down. The drain function allows condensation an escape path from the encoder. The breather/drain must be located at the lowest point

SPECIFICATIONS

ELECTRICAL

- A. Operating Power (Vin)
 - 1. VoltsSee Line Driver Options
 - 2. Current120mA, no load
- B. Output Format
 - 1. 1ØConnector Options H & J
 - 2. 2Ø(A & B)Connector Options E & F
 - 3. 2Ø& Comp.Connector Options A,B,C,M,L,K,V,P, (A,Ä, B,B) N,T,W,X,& Z (differential line driver)
 - 4. Marker1/Rev
- C. Signal TypeIncremental, Square Wave, 50 ±10% Duty Cycle
- D. Direction SensingØA leads ØB for CW rotation as viewed from the back of the tach looking at the non-drive end of the motor.
- E. Transition Sep.15% minimum
- F. Frequency Range0 to 150,000 Hz.
- G. PPR.....240, 256, 300, 480, 512, 600, 960, 1024, 1200
- H. See Line Driver Options

MECHANICAL

- A. Shaft Inertia0.08 to 0.23 oz. In.²
- B. Acceleration5,000 RPM/Sec.
- C. Speed5,000 RPM for all M4 models, except those shown below
.....3,600 RPM for M4-6, M4-7, M4-D, M4-E
- D. Weight7 lbs.

- E. Starting Torque1.5 to 20 oz. In.
- F. Shaft Dia. Tolerance:..See drawing on last page.
- G. Shaft Engagement: See drawing on last page.

ENVIRONMENTAL

- A. Enclosure RatingSealed against dust and water ingress.
- B. Operating Temp.-20 to 85°C

LINE DRIVER OPTIONS

	Output Options			
	1	2	3	4
Voltage Input (Vin)	5-24 VDC	5-18 VDC	18-24 VDC	5-24 VDC
Output High (Volts)	(Vin) -2 (typ)	(Vin) -1 (typ)	330 ohm pull up	5 VDC
Output High (milliamps)	80 (max.)	80 (avg.), 1500 (peak)	330 ohm pull up	80 (max.)
Output Low (Volts)	0.5 (typ)	0.5 (typ)	1 (max.)	0.5 (typ)
Output Low (milliamps)	80 (max.)	80 (avg.), 1500 (peak)	50 (avg.)	80 (max.)
Protection	Reverse Voltage, Transient, Short Circuit (high & low)	Reverse Voltage, Transient, Short Circuit (none)	Reverse Voltage, Transient, Short Circuit (low)	Reverse Voltage, Transient, Short Circuit (high & low)
Maximum Cable Drive(Feet)	1000 ft. @ 5 V 500 ft. @ 12 V 200 ft. @ 24 V	2000 ft.	1000 ft.	1000 ft. @ 5 V

of the encoder and have a clear, unrestricted drainage path. If for any reason the breather/drain cannot be located at the lowest point or have a clear, unrestricted drainage path it must be replaced with a 1/8 NPT pipe plug and the M4 operated as a sealed tach.

WIRING INSTRUCTIONS

The M4 can be wired for single phase, two-phase, either with or without complements, with or without markers. See connector options and wiring diagrams below.

For bidirectional operation of the encoder, proper phasing of the two output channels is important. Phase A channel leads phase B channel for clockwise shaft rotation as viewed from the anti-drive or accessory end of the motor (M4 mounting end).

CORRECTIVE ACTION FOR PHASE REVERSAL

- 1) **Remove Power.**
- 2) Exchange wires on cable, either at encoder cable end, or at speed controller end (but not both).
 - a) **Single Ended 2 Phase Wiring** (see wiring diagram)
Exchange A and B at the use end of the wires.
 - b) **Differential 2 Phase Wiring** (see wiring diagram)
Exchange **either** A with \bar{A} in the phase A pair **OR** B with \bar{B} in the phase B pair but **NOT** both.
- 3) Apply Power.
- 4) Verify encoder feedback is correct, using hand rotation of shaft, or jog mode of the speed controller.

Interconnecting cables specified in the wire selection chart are

based on typical applications. Refer to the system drawing for specific cable requirements where applicable.

Physical properties of cable such as abrasion, temperature, tensile strength, solvents, etc., are dictated by the specific application. General electrical requirements are: stranded copper, 22 thru 16 gauge (Industrial EPIC Connector options can use 14 AWG), each wire pair individually shielded with braid or foil with drain wire, 0.05 uF maximum total mutual or direct capacitance, outer sheath insulator, 1,000 ft. max. See Wire Selection Chart for some suggested cables.

NOTE

When using the plug-in industrial EPIC connector ("P", "V", "X", "Z" options), the wire ends must be tinned with solder before connection at the screw terminals.

WIRING DIAGRAMS

DIFFERENTIAL TWO PHASE WIRING APPLICATIONS

(USE CONNECTOR OPTION "L" FOR M738 AND M785 REPLACEMENTS)

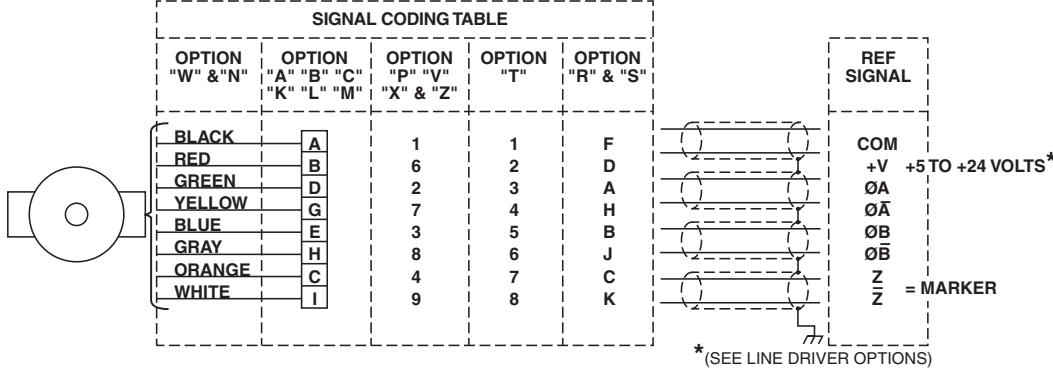

SINGLE ENDED TWO PHASE WIRING APPLICATIONS

(USE CONNECTOR OPTIONS "E" & "F" FOR M737A REPLACEMENTS)

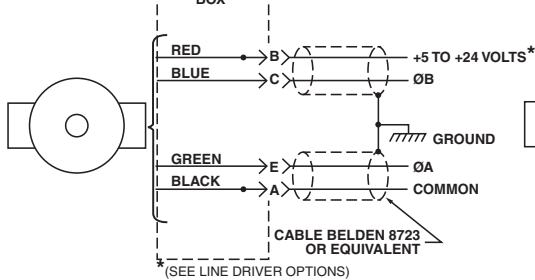

SINGLE ENDED SINGLE PHASE WIRING APPLICATIONS

(USE CONNECTOR OPTIONS "H" & "J" FOR M727A REPLACEMENTS)

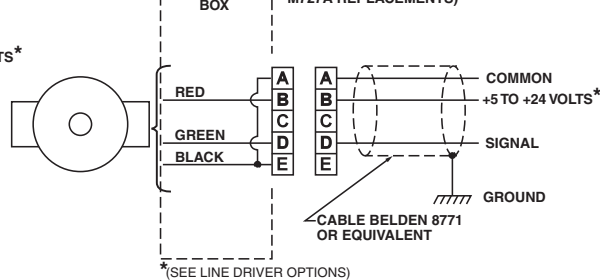

TYPICAL WIRE SELECTION CHART
for 18 AWG, multiple pair, individually shielded

	BELDEN	ALPHA
2 PAIR	9368	6062
3 PAIR	9369	6063
4 PAIR	9388	6064
6 PAIR	9389	6066

NOTES: Marker output for connector options "E" & "F" - Pin "D"
Marker output for connector options "H" & "J" - Pin "C"
Avtron standard warranty applies. Copies available upon request.
Specifications subject to change without notice.

OUTLINE DRAWING

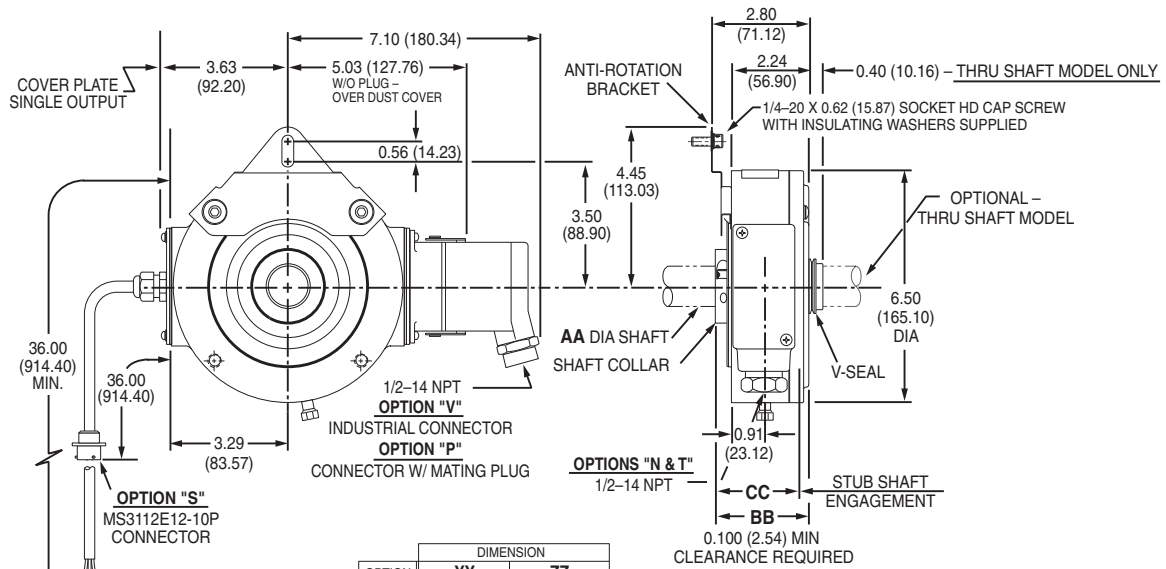

OPTION	DIMENSION	
	YY	ZZ
E & H	3.34 (84.84)	
F, J, & K	5.62 (142.75)	
M	2.75 (69.85)	
L	5.44 (138.18)	

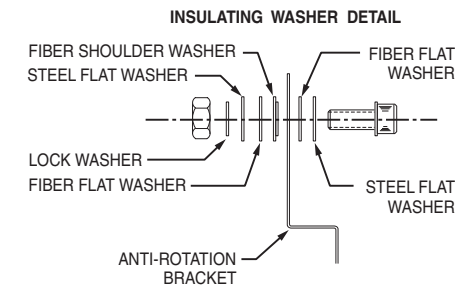
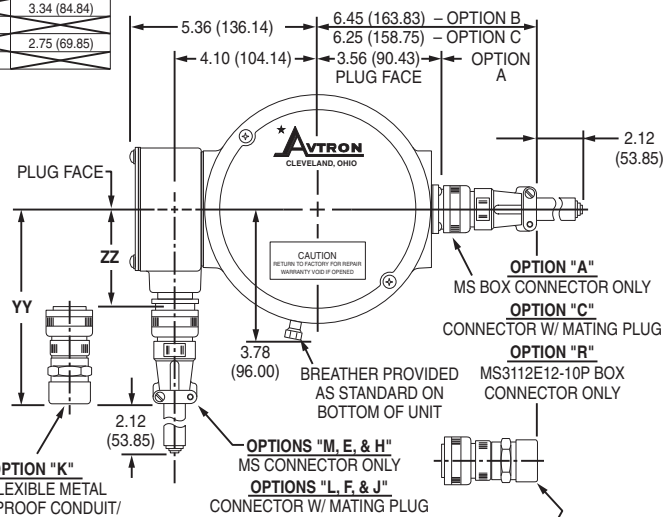
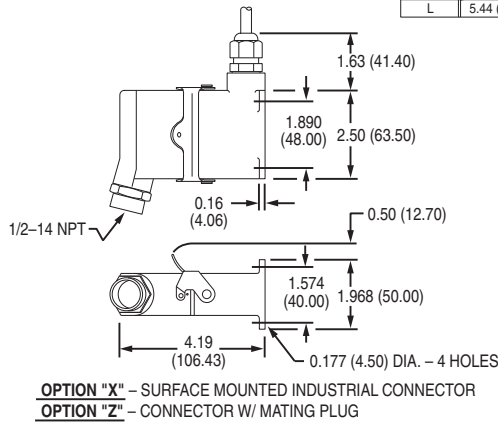

SHAFT OPTION	DIMENSION		
	AA MOTOR SHAFT OD	BB LENGTH	CC MIN/MAX ENGAGEMENT
3	0.6250/0.6245 (15.8750/15.8623)	2.70 (68.58)	1.500/2.000 (38.100/50.800)
4	1.0000/0.9995 (25.4000/25.3873)	2.70 (68.58)	1.500/2.230 (38.100/56.642)
5	1.1250/1.1245 (28.5750/28.5623)	2.70 (68.58)	1.500/2.230 (38.100/56.642)
6	2.0000/1.9990 (50.8000/50.7746)	2.88 (73.15)	2.250/2.500 (57.150/63.500)
7	2.3750/2.3740 (60.3250/60.2996)	3.00 (76.20)	2.250/2.620 (57.150/66.548)
8	1.5000/1.4995 (38.1000/38.0873)	2.88 (73.15)	2.250/2.500 (57.150/63.500)
9	1.6250/1.6240 (41.2750/41.2496)	2.88 (73.15)	2.250/2.500 (57.150/63.500)
A	0.7500/0.7495 (19.0500/19.037)	2.70 (68.58)	1.500/2.230 (38.100/56.642)
B	0.4724/0.4720 (12mm h6)	2.70 (68.58)	1.500/2.000 (38.100/50.800)
C	0.6299/0.6294 (16mm h6)	2.70 (68.58)	1.500/2.000 (38.100/50.800)
D	2.0472/2.0464 (52mm h6)	3.00 (76.20)	2.250/2.620 (57.150/66.548)
E	2.2835/2.2827 (58mm h6)	3.00 (76.20)	2.250/2.620 (57.150/66.548)
F	0.9839/0.9835 (25mm g6)	2.70 (68.58)	1.500/2.230 (38.100/56.642)

3 - DIMENSIONS IN PARENTHESIS ARE MILLIMETERS
 2 - ALL DIMENSIONS ARE APPROX.
 1 - WEIGHT: 7LBS.
 NOTES:

EU DECLARATION OF CONFORMITY The Model M4 Encoder has been assessed and type tested against the following Harmonized European Standards: EN 50081-1:1992, EN 50082-1:1998. The Model M4 has been found to be compliant with the requirements of EU Directive 89/336/EEC provided that the following conditions are met: The electrical supply to the M4 must be within specified limits. The electrical supply must offer suitable protection from voltage surges unless the application does not require such protection. On behalf of Avtron Manufacturing: Stephen L D'Henin, Certification Manager, Epsilon Certification Service.

Features and specifications subject to change without notice.
 Avtron standard warranty applies. All dimensions are in inches (mm) approx.

