



8901 E. PLEASANT VALLEY ROAD
 INDEPENDENCE, OHIO 44131-5508
TELEPHONE: (1) 216-642-1230 • **FAX:** (1) 216-642-6037
E-MAIL: tachs@avtron.com • **WEB:** www.avtronencoders.com

Encoder Instructions

M3-3 thru M3-9
M3-A thru M3-F

HOLLOW SHAFT

DESCRIPTION

The Avtron Model M3-3, M3-4, M3-5, M3-6, M3-7, M3-8, M3-9, M3-A, M3-B, M3-C, M3-D, M3-E, and M3-F Hollow Shaft Encoders are speed and position incremental transducers (also known as tachometers or rotary pulse generators). When mounted to a motor or machine, their output is directly proportional to shaft position (pulse count) or speed (pulse rate). The M3 operates down to zero speed and can be used for both control and instrumentation applications.

The M3 Hollow Shaft Encoders eliminate the need for shaft couplings, adapter flanges, or accessory mounting faces. The unit employs a hollow shaft and clamping collar to lock the encoder to the shaft. An anti-rotation bracket prevents rotation of the encoder while allowing for shaft end float.

The enclosures on all Model M3s help protect the internal components from the entry of dust and liquids.

All M3s utilize a photoelectric sensing system. All M3s can be equipped with one or two outputs. Each output is electrically independent and totally isolated. For many applications this feature provides a running spare output by simply interchanging the output connectors.

These outputs are available as single phase; two-phase (A,B) 90° apart for direction sensing; with complements (\bar{A} , \bar{B}), (A Quad B Output), and with marker pulse (Z , \bar{Z}). Output resolution is determined by the PPR (pulses per revolution), times a sensor multiplier. An auxiliary output is available (C, \bar{C}) at 1/4 the base PPR for instrumentation.

Refer to separate instructions for additional information on the shaft grounding option.

INSTALLATION CONSIDERATIONS

The M3 hollow shaft encoder requires a minimum mounting shaft length, a minimum clearance space, and a precise shaft diameter

tolerance for proper mounting. See the table on the back page for shaft requirements by model.

The M3 standard flexible anti-rotation bracket will tolerate $\pm 0.1"$ of shaft end float. Consideration should be taken when positioning the encoder.

CAUTION

Be careful not to damage clamping fingers during handling. Do not tighten clamping collar before installation onto motor shaft. Damaging clamping fingers can affect the quality of installation.

NOTE

In some cases units are shipped with a protective plug in the hollow shaft to help prevent damage. If it is present, it must be removed prior to final installation.

INSTALLATION

Equipment needed for installation

Supplied:

- | | |
|--|----------------------------------|
| 1. M3 Encoder | 7. Washer, Flat 1/4 (2) |
| 2. Clamping Collar | 8. Washer, Spring Lock 1/4 |
| 3. Anti-Rotation Bracket | 9. Washer, Tooth Lock 3/8 (2) |
| 4. Thread Locker (blue) | 10. Nut, Hex 1/4-20 |
| 5. Screw, Button Hd., 3/8-16 x .50 (2) | 11. Washer, Shoulder, Insulating |
| 6. Screw, Socket Hd. Cap. 1/4-20 x .62 | 11. Washer, Flat, Insulating |
| | 12. Anti-Seize Compound (copper) |

Not Supplied:

- 5/32" Hex Wrench (T-Handle Style) (M3-B only)
- 3/16" Hex Wrench (T-Handle Style) (M3-3, -4, -5, -A, -C, -F only)
- 7/32" Hex Wrench (T-Handle Style)
- 1/4" Hex Wrench (T-Handle Style) (M3-6, -8, -9, -D only)
- 5/16" Hex Wrench (T-Handle Style) (M3-7, -E only)
- 7/16" Wrench
- Dial Indicator

M3 PART NUMBERS AND AVAILABLE OPTIONS

Model	Bore Size	Mounting Style	Line Driver	Output Location	PPR	Connector	Modifications	
M3-	0- Non-Standard 3- 5/8" 7- 2 3/8" A- 3/4" B- 12mm 4- 1" C- 16mm 5- 1 1/8" F- 25mm 8- 1 1/2" D- 52mm 9- 1 5/8" E- 58mm 6- 2"	S- End of Shaft T- Thru Shaft G- End of Shaft with Grounding R- Thru Shaft with Grounding	1- 5 to 24 VDC 2- 5 to 18 VDC 3- 18 to 24 VDC 4- 5 to 24 V in, 5 V out	L- Single output left side R- Single output right side D- Dual output	240 600 256 1024 360 1200 480 2048 500 2500 512			000- None 003- Torque Arm Mount 005- -40° C Rating 007- Fan Cover Mount 008- 4.5" C-Face Mount 009- Northstar Pinout 015- Stainless Steel Shaft 016- 8.5" C-Face Mount 023- Dynapar Pinout (MS) 028- 12.5" C-Face Mount 035- Insulated Shaft

Connector

10 Pin Connector			6 Pin MS	5 Pin MS	Conduit Box	3 ft. Flex. Cable
MS	MS mini	EPIC	M940 replacement	M737A replacement	N-	W-
A- without Plug ^s B- with Flex. Conduit Adapter ^s C- with Plug ^s	K- with Flex. Conduit Adapter ^b L- elbow with Plug ^b M- without Plug ^b	P- with Plug V- without Plug	D- with Plug ^b	E- without Plug ^s F- with Plug ^s M727A replacement H- without Plug ^s J- with Plug ^s	N- with color coded leads T- with Terminal Block	W- Sealed, Pigtail X- Sealed, Industrial Connector without Plug Z- Sealed, Industrial Connector with Plug

^s side exit ^b bottom exit

Optional:

- Torque Arm
- Fan Cover Mounting Kit
- C-Face Mounting Kits

Clean machine shaft of any dirt and check for any burrs or damage.

Install the anti-rotation bracket to the back of the M3 using 3/8-16 screws and thread locker.

Remove screws from clamping collar, apply thread locker to screw threads and reinstall. Place clamping collar loosely on the inboard end of the shaft. Carefully slide M3 onto the shaft. **DO NOT FORCE.** Encoder should slide on easily. After verifying M3 fit onto shaft, remove M3, apply anti seize supplied to shaft and re-install M3 (see shaft engagement). Tighten screws on clamping collar evenly until snug, then firmly tighten. **DO NOT USE A STANDARD RIGHT ANGLE WRENCH.** Use only a T-handle hex wrench or torque wrench with hex bit.

Secure free end anti-rotation bracket to frame. Use supplied insulating hardware if necessary as shown. Adapter kits are available for NEMA 56C (A24492) and 8 1/2" (A24493) mounting faces.

Shaft Engagement

For end of shaft mounting applications:

See table on last page.

For shaft lengths greater than the maximum engagement allowed, end of shaft mounting may still be employed by locating the encoder away from the motor using a spacer between the motor and anti-rotation bracket.

Corrective Action for Excess Housing Movement (Wobble)

The hollow shaft M3 design eliminates the potential for bearing and coupling failures from misalignment, however, excessive housing movement (wobble) may cause undesirable vibrations. The higher the RPM, the more severe the vibration will be from housing movement. In a typical installation a housing movement of 0.007" TIR or less (as measured at the outside diameter of the

main encoder body) will not have an adverse effect. If excessive housing movement is detected in the installation:

- 1) Check the shaft the M3 is mounted on for excessive shaft runout. NEMA MG1 calls for 0.002" TIR or less.
- 2) Verify that the M3 engagement with the motor shaft conforms to the engagement rules on page 4. In general, maximizing engagement will minimize housing movement.
- 3) Verify that the mounting shaft diameters conform to the rules on page 4. Excessive housing movement occurs when the clearance between the motor shaft and pulse generator shaft allows the two center lines to miss match.
- 4) Loosen the clamping collar and rotate the motor shaft 180° within the M3 hollow shaft sleeve.
- 5) Make sure the clamping collar is tightened equally on both sides.
- 6) Move the split in the clamping collar over a solid portion of the M3 shaft.

If excessive housing movement still exists after the above steps, it may be necessary to physically bias the attitude of the encoder on the motor shaft while the clamping collar is being tightened. Either by eye or using dial indicators, note the position around the outside diameter of the encoder that is most out of position from true while turning the motor shaft slowly. With the motor shaft no longer turning, loosen the clamping collar. While applying moderate force by hand against the outside diameter of the encoder on the side opposite where the out of true position was observed, retighten the clamping collar. Several iterations may be necessary if the first attempt under or over compensates. This method may be used to help compensate for undersized shafts, shaft runout, bent clamping fingers, and other problems.

WIRING INSTRUCTIONS

The M3 can be wired for single phase, two-phase, either with or without complements, with or without markers and with or without complementary divide by 4. See connector options and wiring diagrams below.

For bidirectional operation of the encoder, proper phasing of the two output channels is important. Phase A channel leads phase B

SPECIFICATIONS

ELECTRICAL

- A. Operating Power (Vin)
 - 1. VoltsSee Line Driver Options
 - 2. Current120mA, no load
- B. Output Format
 - 1. 1ØConnector Options H & J
 - 2. 2Ø(A & B)Connector Options E & F
 - 3. 2Ø& Comp.Connector Options A,B,C,M,L,K,V,P, (A,Ā, B,Ḃ) N,T,W,X, & Z (differential line driver)
 - 4. MarkerAll Options, 1/Rev, Gated with B low @ and below 1200 PPR
 - 5. ÷4 (C,Ā)Connector Options A,B,C,M,L,K,V,P, N,T,W,X, & Z (differential line driver)
- C. Signal Type.....Incremental, Square Wave, 50 ±10% Duty Cycle
- D. Direction Sensing.....ØA leads ØB for CW rotation as viewed from the back of the tach looking at the non-drive end of the motor.
- E. Transition Sep.15% minimum
- F. Frequency Range0 to 150,000 Hz.
- G. PPR240, 256, 360, 480, 512, 600, 1024, 1200, 2048, 2500
- H. See Line Driver Options

MECHANICAL

- A. Shaft Inertia0.08 to 0.23 oz. In.²
- B. Acceleration5,000 RPM/Sec.
- C. Speed.....5,000 RPM for all M3 models, except those shown below
.....3,600 RPM for M3-6, M3-7, M3-D, M3-E

- D. Weight6 lbs.
- E. Starting Torque.....1.5 to 20 oz. In.
- F. Shaft Dia. Tolerance.....See drawing on last page.
- G. Shaft Engagement.....See drawing on last page.

ENVIRONMENTAL

- A. Enclosure RatingSealed against dust and water ingress.
- B. Operating Temp.....-20 to 85°C

LINE DRIVER OPTIONS

	Output Options			
	1	2	3	4
Voltage Input (Vin)	5-24 VDC	5-18 VDC	18-24 VDC	5-24 VDC
Output High (Volts)	(Vin) -2 (typ)	(Vin) -1 (typ)	330 ohm pull up	5 VDC
Output High (milliamps)	80 (max.)	80 (avg.), 1500 (peak)	330 ohm pull up	80 (max.)
Output Low (Volts)	0.5 (typ)	0.5 (typ)	1 (max.)	0.5 (typ)
Output Low (milliamps)	80 (max.)	80 (avg.), 1500 (peak)	50 (avg.)	80 (max.)
Protection	Reverse Voltage, Transient, Short Circuit (high & low)	Reverse Voltage, Transient, Short Circuit (none)	Reverse Voltage, Transient, Short Circuit (low)	Reverse Voltage, Transient, Short Circuit (high & low)
Maximum Cable Drive(Feet)	1000 ft. @ 5 V 500 ft. @ 12 V 200 ft. @ 24 V	2000 ft.	1000 ft.	1000 ft. @ 5 V

channel for clockwise shaft rotation as viewed from the anti-drive or accessory end of the motor (M3 mounting end).

CORRECTIVE ACTION FOR PHASE REVERSAL

- 1) **Remove Power.**
- 2) Exchange wires on cable, either at encoder cable end, or at speed controller end (but not both).
 - a) **Single Ended 2 Phase Wiring** (see wiring diagram)
Exchange A and B at the use end of the wires.
 - b) **Differential 2 Phase Wiring** (see wiring diagram)
Exchange **either** A with \bar{A} in the phase A pair **OR** B with \bar{B} in the phase B pair but **NOT** both.
- 3) Apply Power.
- 4) Verify encoder feedback is correct, using hand rotation of shaft, or jog mode of the speed controller.

Interconnecting cables specified in the wire selection chart are based on typical applications. Refer to the system drawing for specific cable requirements where applicable.

Physical properties of cable such as abrasion, temperature, tensile strength, solvents, etc., are dictated by the specific application. General electrical requirements are: stranded copper, 22 thru 16 gauge (Industrial EPIC Connector options can use 14 AWG), each

wire pair individually shielded with braid or foil with drain wire, 0.05 uF maximum total mutual or direct capacitance, outer sheath insulator, 1,000 ft. max. See Wire Selection Chart for some suggested cables.

NOTE

When using the plug-in industrial EPIC connector ("P", "V", "X", "Z" options), the wire ends must be tinned with solder before connection at the screw terminals.

WIRING DIAGRAMS

DIFFERENTIAL TWO PHASE WIRING APPLICATIONS

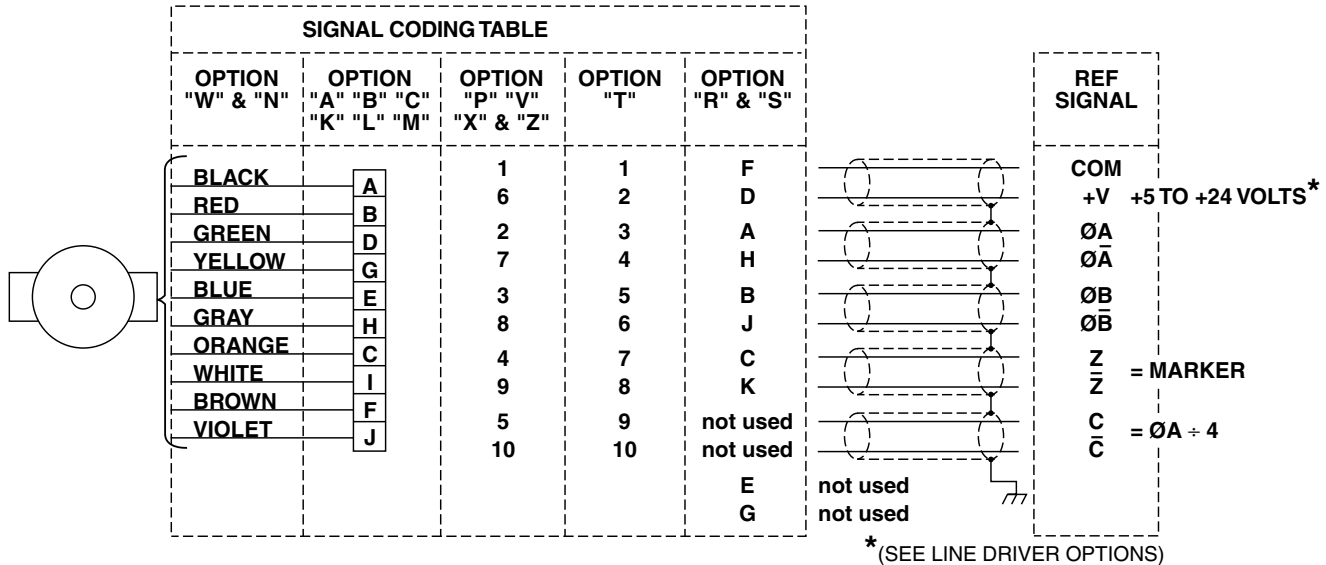

SINGLE ENDED TWO PHASE WIRING APPLICATIONS

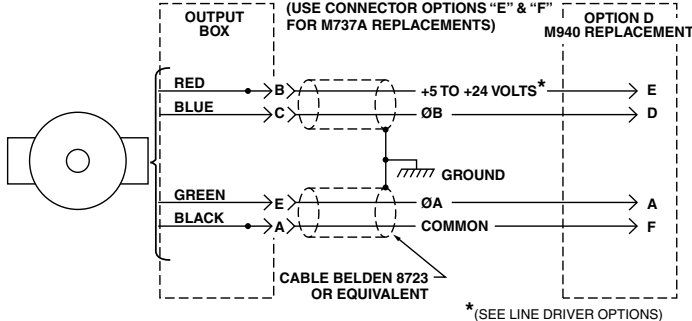

SINGLE ENDED SINGLE PHASE WIRING APPLICATIONS

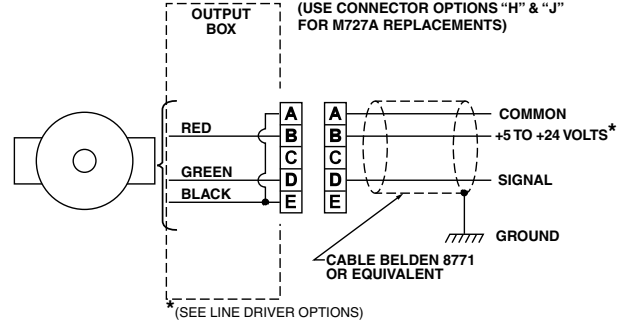

TYPICAL WIRE SELECTION CHART for 18 AWG, multiple pair, individually shielded

	BELDEN	ALPHA
2 PAIR	9368	6062
3 PAIR	9369	6063
4 PAIR	9388	6064
6 PAIR	9389	6066

NOTES: Marker output for connector options "E" & "F" - Pin "D"
 Marker output for connector options "H" & "J" - Pin "C"
 Avtron standard warranty applies. Copies available upon request.
 Specifications subject to change without notice.

OUTLINE DRAWING

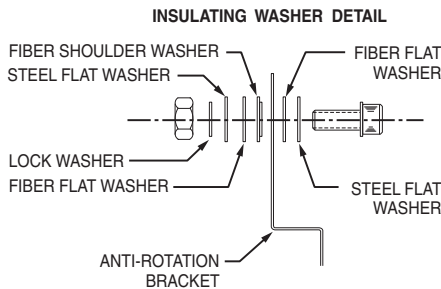
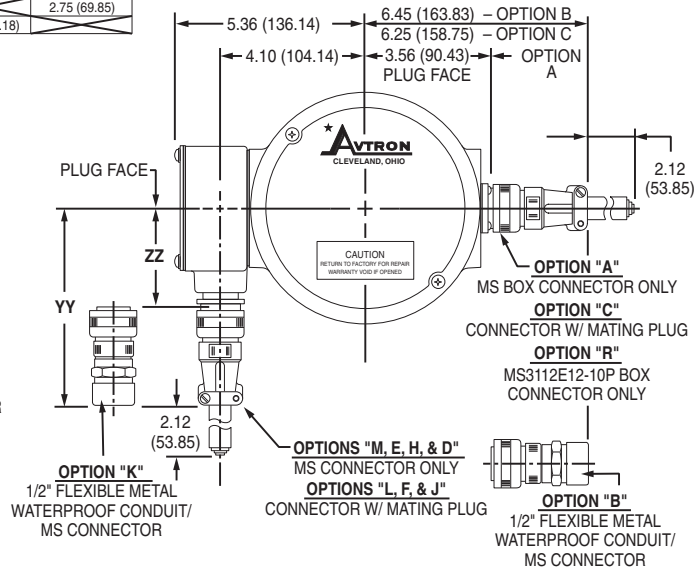
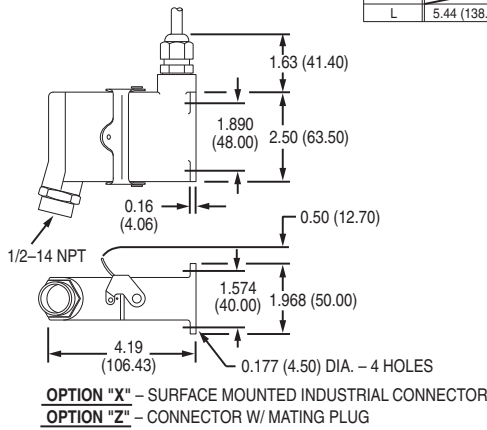
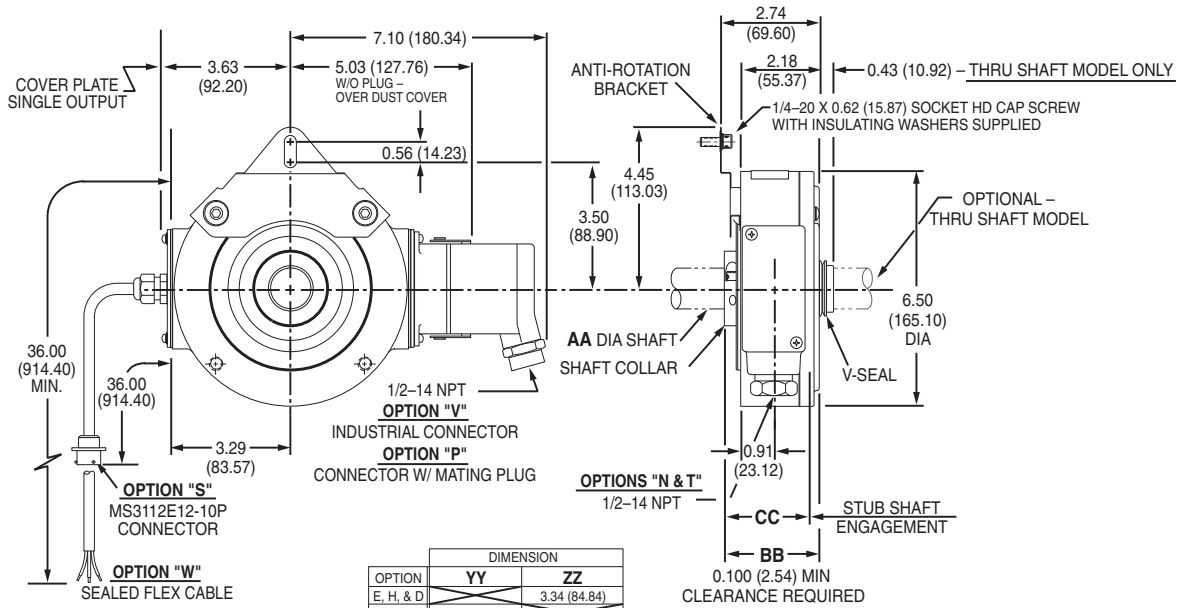

3 - DIMENSIONS IN PARENTHESIS ARE MILLIMETERS
 2 - ALL DIMENSIONS ARE APPROX.
 1 - WEIGHT: 6 LBS.
 NOTES:

SHAFT OPTION	DIMENSION		
	AA MOTOR SHAFT OD	BB LENGTH	CC MIN/MAX ENGAGEMENT
3	0.6250/0.6245 (15.8750/15.8623)	2.70 (68.58)	1.500/2.000 (38.100/50.800)
4	1.0000/0.9995 (25.4000/25.3873)	2.70 (68.58)	1.500/2.230 (38.100/56.642)
5	1.1250/1.1245 (28.5750/28.5623)	2.70 (68.58)	1.500/2.230 (38.100/56.642)
6	2.0000/1.9990 (50.8000/50.7746)	2.88 (73.15)	2.250/2.500 (57.150/63.500)
7	2.3750/2.3740 (60.3250/60.2996)	3.00 (76.20)	2.250/2.620 (57.150/66.548)
8	1.5000/1.4995 (38.1000/38.0873)	2.88 (73.15)	2.250/2.500 (57.150/63.500)
9	1.6250/1.6240 (41.2750/41.2496)	2.88 (73.15)	2.250/2.500 (57.150/63.500)
A	0.7500/0.7495 (19.050/19.037)	2.70 (68.58)	1.500/2.230 (38.100/56.642)
B	0.4724/0.4720 (12mm h6)	2.70 (68.58)	1.500/2.000 (38.100/50.800)
C	0.6299/0.6294 (16mm h6)	2.70 (68.58)	1.500/2.000 (38.100/50.800)
D	2.0472/2.0464 (52mm h6)	3.00 (76.20)	2.250/2.620 (57.150/63.500)
E	2.2835/2.2827 (58mm h6)	3.00 (76.20)	2.250/2.620 (57.150/63.500)
F	0.9839/0.9835 (25mm g6)	2.70 (68.58)	1.500/2.230 (38.100/56.642)

EU DECLARATION OF CONFORMITY: The Model M3 Pulse Generator has been assessed and type tested against the following Harmonized European Standards: EN 50081-1:1992, EN 50082-1:1998. The Model M3 has been found to be compliant with the requirements of EU Directive 89/336/EEC provided that the following conditions are met: The electrical supply to the M3 must be within specified limits. The electrical supply must offer suitable protection from voltage surges unless the application does not require such protection. On behalf of Avtron Manufacturing: Stephen L D'Henin, Certification Manager, Epsilon Certification Service.

Features and specifications subject to change without notice.
 Avtron standard warranty applies. All dimensions are in inches (mm) approx.



8901 E. PLEASANT VALLEY RD., INDEPENDENCE, OH 44131, U.S.A. • (1) 216-642-1230 • FAX (1) 216-642-6037 • www.avtronencoders.com



REV. 10-17-06