

Avtron M6 Hollow Shaft

Explosion Protected, Magnetic Hollow Shaft Mount Encoder, 1" to 2 3/8"



16 lbs. of Tough Encoder!

- Explosion protected
- Flameproof
- Heavy, Mill Duty
- Up to 1200 PPR
- Immune to water, oil, dust, dirt, etc.
- Withstands extreme shock and vibration
- Extra heavy-duty bearings
- Optional dual isolated outputs
- Does not require intrinsic safety barriers
- ATEX/CENELEC certified for Zone 1 applications
- Excellent for oil drilling and gas pipeline applications

M6-4 thru -7 explosion protected heavy mill duty encoders are designed for direct mounting on motor or load shafts, from 1" to 2 3/8". Other models offer, respectively, face mount (M6-1) and foot mount (M6-2) using a coupled solid shaft.

Forget fragile glass disk encoders! The M6 features Avtron's rugged magnetic sensor and solid metal rotor tech-

nology. Our shatterproof, moisture proof systems ensure your application has maximum uptime.

No more tiny stub shafts on big motors or load shafts! The hollow shaft (tethered) models offer direct mounting on big shafts, from 1" to 2 3/8", without flanges, reducers, couplings, or other hardware. No rework is needed; just mount the encoder directly on the

shaft, and secure the tether arm. The heavy duty bearings withstand runout and vibration that destroy lesser encoders.

Why buy an "explosion proof" encoder that requires protection from the slightest bump or raindrop? Pick an M6 explosion protected, heavy duty, solid shaft encoder!



QUALITY SYSTEM CERTIFIED TO ISO 9001
www.avtronencoders.com

M6 Magnetic, Hollow Shaft Encoder (1" to 2 3/8")

OUTLINE DRAWING

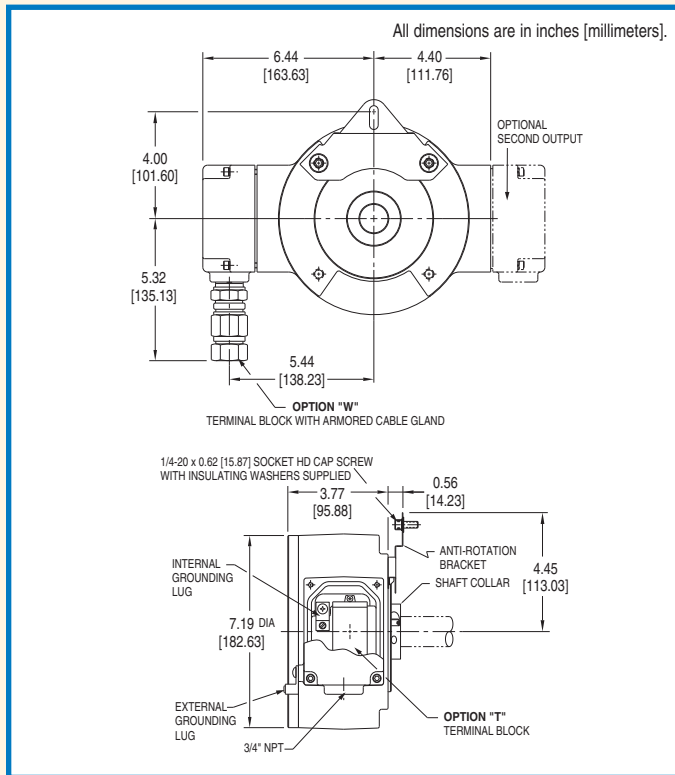

Check out our web site for more detailed specifications, drawings, and installation instructions.

www.avtronencoders.com

MORE M6 ADVANTAGES

- Threaded rod torque arm for easy mounting
- Highly resistant to electrical and magnetic motor and brake noise
- Second isolated output may be different PPR
- Available armored wire gland
- IP66 Enclosure

M6 SPECIFICATIONS

Operating Power: 5-24 VDC; Current 120mA, no load

Output Format: A, \bar{A} , B, \bar{B} ; Optional Marker Z, \bar{Z}

Frequency Range: 0 to 100 KHz

PPR: 240-1200

Speed: 5000 RPM Max. Std., 5/8" to 1 5/8" shaft

3600 RPM Max. Std., 2" to 2 3/8" shaft

(for higher speeds, consult factory)

Temperature: -20° to 80°C

Chemical: Polyurethane enamel paint protects against salt spray, mild acids, and bases

Explosion Protection: CE 0539 Ex IIC 1 G  

EEx de IIC T4 (Tamb -20° to 80°C)

Weight: 16 lbs.

SELECTION GUIDE

Model	Bore Size	Mounting Style	Line Driver	Left & Right Output Range	Base PPR	Marker	Connector	Modifications
M6-	0- Non-Standard 4- 1" 5- 1 1/8" 6- 2" 7- 2 3/8"	S- End of Shaft	1- 5 to 24 VDC 2- 5 to 18 VDC 3- 18 to 24 VDC	X- None L- Low Range (Base PPR x 1/2) M- Medium Range (Base PPR x 1) H- High Range (Base PPR x 2)	48- 480 51- 512 60- 600	Z- Marker -- None	T- Conduit Box, Terminal Block, 3/4" NPT W- Conduit Box, Terminal Block and Wire Gland	000- None/No Torque Arm 003- Torque Arm B28390

All dimensions are in inches [millimeters].
Specifications and features are subject to change without notice.

